

*Hobie* **mirage** *Kayaks*  
Assembly Manual



Hobie Mirage™ Revolution

# Welcome to the Hobie Way of Life



***Thank you for choosing a Hobie Mirage™ Kayak. As a member of the Hobie way of life, you are now on the road to pure adventure in pedaling and paddling. This owner's manual is designed to help you get maximum enjoyment from your new Hobie kayak. But more important, it is designed to help you use it safely. The content of this manual covers all Mirage kayaks.***

# About the Design of your Kayak



## Sit-on-top Cockpit

Hobie Mirage™ Kayaks are open-top cockpit designs. This allows the kayaker to enter and exit the kayak easily from the shore, dock or water. Scupper hole(s) make the kayak self-bailing. The design also eliminates the need to perform an “Eskimo roll” (advanced kayak technique). The contoured seat is fitted with an adjustable backrest for added comfort.

## Hull Design

The long center “keel” area encourages the kayak to track straight when paddling and coasting. Under moderate paddling conditions, the wider “shoulder” area of the hull rides high at the surface of the water without compromising speed. If the kayak is fully loaded with gear or is being paddled and braced in rough conditions, the “shoulder” areas provide secondary buoyancy and stability.

## Maneuverability

All new Mirage Kayaks come with the patent pending Twist-and-Stow rudder system. This system comes pre-installed by our factory. This new rudder is designed to flip out of the way during land transport and has an optional larger rudder blade for more turning authority with the kayak sailing option.

## Scupper Hole(s)

Drain holes (scuppers) in the cockpit or cargo well allow any water that enters the cockpit to immediately flow back out.

## Graphics

Graphics are molded into the kayaks, so they will not peel or flake off for the life of the boat.

# Hobie MirageDrive

## Drive Installation

1. The Hobie MirageDrive™ must be lowered into the opening of the hull near the footwells so it is facing forward and evenly front to back. The front of the MirageDrive can be determined by the location of the fin masts. Tipping the drive forward or aft when lowering can cause it to wedge into the well and possible cause damage to the hull.

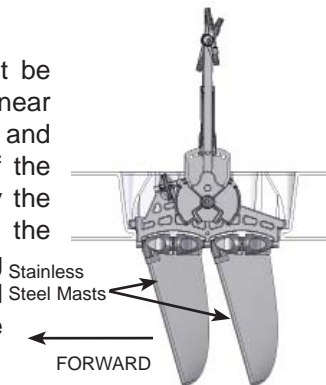

2. To lock the Drive into the hull, lower the Drive into the hull so that the drum shaft posts drop down into the Click-N-Go cams and lock into place.

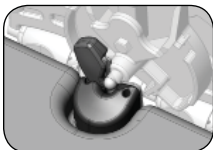

3. To remove the MirageDrive™, flip the Click-N-Go cam back and pull the drive out. The cams should automatically reset themselves for installation, but if they do not just flip the cam forward.

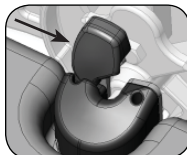

## Pedal Adjustment

The pedals of the Hobie MirageDrive are adjustable to accommodate different leg lengths of kayakers. To adjust the pedals:

1. Squeeze the adjuster handles located on the pedal cranks.

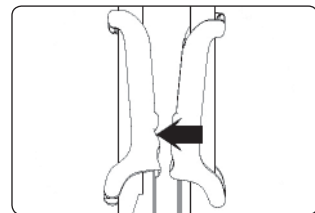

2. While squeezing the adjuster handle, move the pedal crank to the most comfortable position. Like a bicycle, it is best to adjust the pedals so your legs do not fully extend causing your knees to lock. Make sure that the metal pin on the crank fully engages the adjustment hole.

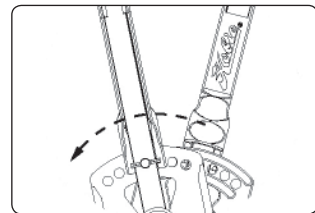

3. Hobie Cat recommends new users to have the pedal length adjustment set in the middle (number 4) to help while installing it into the hull correctly. Once installed you can select your preferred length setting.

## Drum Casting

When turning the nut with a 7/16 inch open-end wrench, only giving it one half a turn at a time, then do the same to the remaining three nuts. Re-check the tension and adjust accordingly.

Note: Keep the pedal shafts and masts parallel. When the shafts are together, both masts must be straight down. The idler pulley cable (see item B in the illustration below) will be tightened automatically when the front chain assembly is tightened.

## Cable Adjustments

### ***Determining if adjustment is needed...***

Occasionally the cables may need to be re-tightened. The cables should be kept taut; however, the front chain should be a little tighter than the rear chain. Push with your thumbs at the points marked (A) with moderate pressure (see the image to the right). The side of the chain should not go beyond the inside edge of the drum casting.

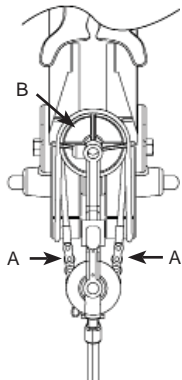

## Washing

After using in salt water or dirty water, wash the Hobie MirageDrive™ with fresh water. Allow to dry, then spray metal parts with WD-40™ or equivalent. Special attention should be paid to threaded cable ends, lock nuts, chain, shafts, pedals, and adjustment pins.



## Miscellaneous Maintenance

Periodically check for loose screws or frayed cables. If a cable has a broken strand, replace it with new cable.

### **CAUTION**

Care should be taken to avoid striking objects with the Hobie MirageDrive. If you bend a mast, it usually can be straightened. To straighten, remove the MirageDrive from the boat and insert the Drive into something solid, such as a vise. Remove the fin, then carefully bend the mast until straight. To test for "true", roll the mast on a flat surface and straighten as needed until the masts roll evenly. If the mast cannot be straightened or becomes cracked or fatigued, replace the mast.

# Twist-and-Stow Rudder System Patent Pending

## Twist-and-Stow Rudder Features

The Twist-and-Stow rudder system is pre-installed and adjusted at the factory. With extensive use, the rudder system may need to be adjusted. The following information is intended to familiarize you with the rudder and how it works.

The left steering control line is tied off at the screw here.



The right steering control line passes up through the hole here and is tightened down with the small screw alongside it.

The left steering control line passes up through the hole in the hex head bolt.

These bolts give you the ability to change between a larger or smaller rudder blade.

For improved performance with the kayak sailing option, an optional larger rudder blade is available.

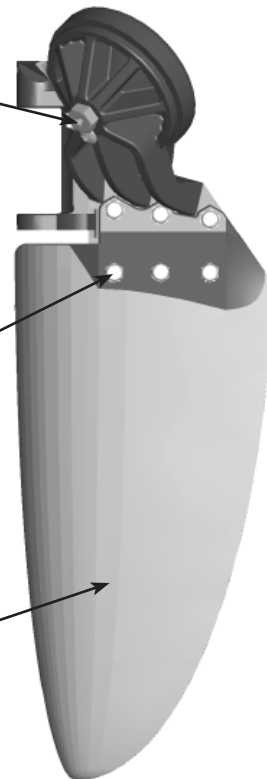

## Up/Down Control Assembly/ Operation

The following detail explains how the up/down rudder control is set up inside the kayak.

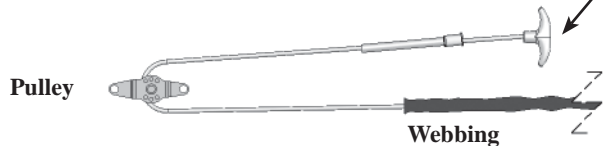

**T Handle:** There are two T-handles on the kayak that operate the up/down control function of the rudder. Simply pull on the UP handle to raise the rudder and the DOWN handle to lower the rudder. When the rudder is down, it is automatically held down with a detent. If you desire more holding force, pull the line tight and jam it into the cleat near where the T-handle exits the hull.

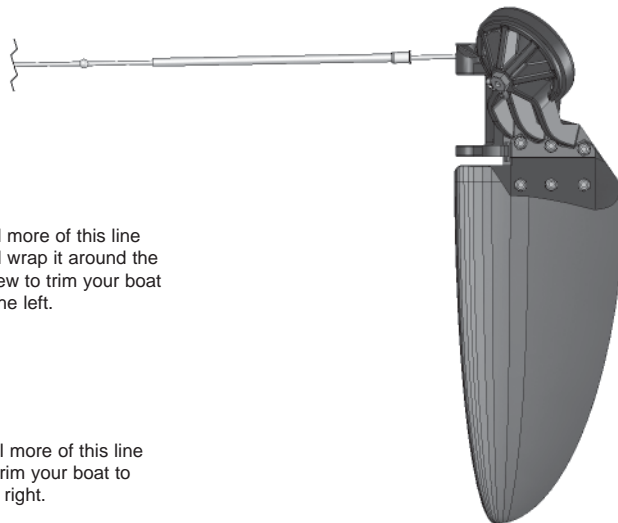

## Steering Control Trim

To achieve a good, responsive feel with the steering system, you may occasionally need to adjust the tension of the steering lines (follow the diagram at right).

These two screws hold the end of the line in place. Turn back the screw a couple of times to release the end of the line and tighten the screws back down to hold the line.

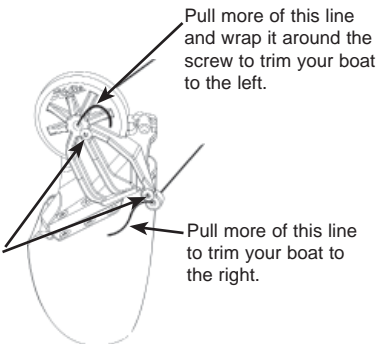

Pull more of this line and wrap it around the screw to trim your boat to the left.

Pull more of this line to trim your boat to the right.

# Basic Kayak Information



Hobie Mirage™ Outfitter

## **Basic Kayak Features**

The front of the boat is the “bow” and the rear is the “stern”. When looking forward to the bow, the left side of the boat is “port” and the right side is “starboard”. The hull ID number can be found on the bottom of the boat, at the stern.

In the middle of the boat, there is a cockpit area, with the seat (toward the stern) and footwells (toward the bow). Inside the cockpit are scupper hole(s) that go all the way through the boat. These scuppers allow the boat to drain. Your particular model may have hatches that allow access to the inside of the boat for gear storage.

Alongside the cockpit are a series of small “U” straps, called pad eyes. These are used to attach accessories such as backrests.

All Hobie kayaks are made of linear polyethylene, making them repairable and recyclable.

## **Recommended Equipment for Specific Types of Pedaling and Paddling**

*Basic Boating:* Life Jacket, Paddle, Paddle Leash, Backrest, Safety Whistle, Filled Water Bottle, Appropriate Safety Equipment.

*Longer Distance Touring:* Dry Bags, Chart, Compass.

*Additional Equipment for Diving:* Dive Flag, Anchor.

*Fishing:* Fishing Rod Holder, Drip Guards, Gear Bags, Knee Braces, Anchor.

## **Safety**

Paddle/pedal sports can be dangerous and physically demanding. The user of this product should understand that participating in kayaking may involve serious injury or death. Observe the following safety standards when using this product. These are basic safety rules that all boaters should follow. Always use common sense and follow all safety rules at all times.

## Safety Checklist

- To avoid damage to the Hobie MirageDrive™, push either pedal completely forward before beaching or in shallow water. Use small, partial pedal strokes with one pedal nearly all the way forward until there is adequate water depth for the MirageDrive to have complete clearance in the water.
- Consult your physician prior to beginning paddle/pedal sports.
- Always carry the spare paddle provided with the boat.
- Obtain paddle/pedal sports instructions from your dealer specific to this type of craft.
- Obtain certified first aid training and carry first aid and rescue/safety equipment.
- Always wear a Coast Guard approved personal flotation device.
- Wear a helmet where appropriate.
- Dress appropriately for weather conditions; cold water and/or weather can result in hypothermia.
- Check your equipment prior to each use for signs of wear or failure.
- Never pedal or paddle alone.
- Always tie a leash to your paddle.
- Do not pedal or paddle in flood conditions.
- Care must be made to ensure that the access hatches on your kayak remain closed while on the water. Water can enter a hatch that is left open and possibly flood the hull making the boat unstable or cause inadequate flotation for the passenger(s).
- Be aware of appropriate river water levels, tidal changes, dangerous currents, obstacles in and above the water and weather changes.
- Scout unfamiliar waters; portage where appropriate.
- Do not exceed your paddling/pedaling ability; be aware of your limitations.
- Hobie Kayaks were not designed for fast moving water.

- Follow the manufacturer's recommendations for use of this product.
- If additional outfitting is added to this craft, use manufacturer-approved materials only; do not impair entry or exit access.
- Read owner's information package prior to using this product.
- The user of this product acknowledges both an understanding and assumption of the risk involved in paddle/pedal sports.
- When paddling in a new area, check with the locals regarding currents, shoreline conditions and weather patterns. Plan an "escape route" -- an alternative place to get off the water should environmental conditions dictate. Beware of offshore winds that may make it difficult to return to shore.
- DO NOT use alcohol or mind-altering drugs prior to or while using this product.

## The Shakedown Cruise

As with any new product, it is important that you become familiar with the craft and all its features. It is also important to determine if the kayak is sound before long trips. We recommend that you do what we call a "shakedown cruise" when the kayak is new, after shipping or transport, before long trips and after installing any through hull fittings. This test is typically done in shallow, calm conditions where you can familiarize yourself with the boat or test the boat before taking any long trips into open water. Things that you should check or practice are

- Rudder Operation
- MirageDrive Adjustment
- Practice getting in and out of the kayak from a capsized state
- Drain plug locations to make sure they are properly installed
- Closing the hatches properly
- Taking the kayak sail down on the water (if applicable)



HOBIEKAYAKS.COM



## **How to Perform a Self Rescue**

If you fall out of your boat, don't panic. Stay with the boat. You should be wearing a life jacket which will keep you afloat. There are many ways to get back up on the boat.

If the boat is upside-down, it will need to be turned over. To do this, reach across the bottom of the boat and grab the scupper hole or Hobie MirageDrive™ and pull the boat upright.

Position yourself so your head is near the cockpit area of the boat and you are facing the boat. You will want to be between the seat and the footwell areas of the boat.

Reach across the boat to the far edge with one hand. Place the other hand on the near-side rail, then kick with your feet, pulling yourself up and onto the boat, so your belly is across the center line of the boat. (Your belly should end up between the footwells and the seat.)

Next, roll over onto your backside toward the seat, which should place your backside in the seat. Sit up, swing your feet into the footwells and you're ready to go.

The key to this method is to keep your center of gravity low and near the centerline of the boat. Your body and head should stay close to the boat.

**CAUTION:** While righting the Hobie Mirage or climbing back aboard, stay clear of the pedals, pedal shafts, sails and adjustment straps. Avoid being hit by them or getting them hooked on your life jacket.

If your kayak turns over with the kayak sail up, it can be very difficult to turn the kayak over by rolling just the kayak. Make sure that the mainsheet is loose so that the sail is free to move around.

## **Pedaling**

First adjust the pedals to accommodate your size as shown a few pages back. Adjustments can be made for a variety of leg lengths. Adjust the pedal positions equally. Sit with one pedal all the way forward so your knee stays slightly bent when your leg is fully extended. Then you simply pedal back and forth to propel the boat forward. For pedaling in shallow water, partial strokes with one pedal forward and one aft allow for retractment of the sails in shallow water. When there is adequate water for clearance of the fins, full strokes can be used. For additional speed you can paddle as well as pedal.

Before beaching or launching, push one pedal completely forward to retract the Hobie MirageDrive fins up against the hull and kick up the rudder by flipping the lever on the right side of the boat to the forward (rudder up) position. To take off from the beach, push out to deeper water or paddle out before putting the rudder down and pedaling the MirageDrive.

If launching from a rocky or wavy shore, to avoid damage to your MirageDrive, paddle into deeper water before installing it. (Be sure to tether the MirageDrive to your kayak when it is not installed.) You may also prefer to remove the drive before beaching.

## Padding

You can choose to paddle, pedal or combine the two. These guidelines will help you to get started.

To start, sit in your kayak. Your backside should be all the way back in the seat and your knees comfortably bent. To find the proper footwell, straighten your legs all the way out and then bring them back one "well". If your legs are too outstretched, you may experience strain on your lower back. If your knees are bent too much, you may end up knocking your kneecaps while paddling.

For proper hand placement on your paddle, start with your hands about a shoulder's width apart and centered. If you place the center of the paddle on top of your head, your elbows should form slightly less than a 90 degree angle. There should be an equal amount of paddle shaft beyond each of your hands.

Some paddles may have the blades offset, or "feathered", at some degree from parallel. A feathered paddle presents less surface area for the wind to catch as that blade moves



forward through the air. Some paddles have a flattened spot along the paddle shaft that will help keep your "control" hand in a fixed position. However, a special technique must be used to get each blade in the water. If the paddle is right-hand controlled (when the right blade is held vertical, the left blade "scoop" is pointed mostly up), the right hand will stay tight and the left hand loose. To learn the process, hold the paddle tight in your right hand and loose in your left. Using the right hand, rotate the paddle blade back and forth; it should spin in your left hand. Now take a stroke on your right, then cock your right wrist back (left hand staying loose and somewhat open) and take a stroke on your left. If using a left-hand control paddle, reverse the process. The left hand stays tight and the right hand loose.

The basic paddle stroke will give you forward power. Place a paddle blade in the water near your toes. Pull the paddle blade back alongside the boat to approximately your hip area while your opposite hand and paddle blade move forward. Then lift the first paddle blade out of the water while lowering the second blade into the water and take a stroke with the other side.

If you pull the paddle out and away from the hull in an arc, it will force the bow of the boat to swing away from the paddle blade. This is called a "sweep stroke" and is used to turn the boat.

## **More Paddling Tips**

Hobie kayaks are very easy to use and very forgiving. By beginning in calm water, you can quickly get the feel of the boat and paddle techniques. Practice getting in and out of the boat by yourself.

Relax your hands when paddling; a tight grip is not necessary!

Sit with good posture while keeping your torso vertical. Choose a footrest position that will allow your knees to be slightly bent.

For greater efficiency use not only your arms, but your torso and shoulders as well. Start out easy until you get the feel of the paddle and the steering strokes. Most experienced paddlers use an offset (feathered) paddle, but beginners may prefer to keep the paddle blades square.

## **Mirage Scupper Plug**

You Hobie Mirage kayak is shipped with a Mirage Cassette Plug. The plug is provided as standard equipment in the Mirage Kayak package and is used to fill the space where the Mirage fits into the hull. It is inserted when the MirageDrive is removed to provide added safety and to “fair” the bottom of the hull when paddling.

To install the cassette plug, simply place the plug in the hole for the MirageDrive™ mechanism and lock it down using the Click-n-Go cams.

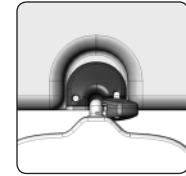
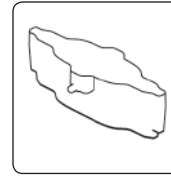

## **Storing Your Hobie Kayak**

Hobie has chosen a blend of plastic that has an added measure of ultraviolet inhibitors to provide superior protection from ultraviolet light. However, to ensure extra years of flexibility and bright colors, avoid storing the boat where it will be exposed to weather or in direct sunlight.

Kayaks should be stored upside down on the cockpit rails, or suspended in the air. When hanging your kayak, make sure that the ropes or straps support most of the weight on the cockpit rails or the side of the boat. A word of caution: hanging by the scupper hole(s) may cause distortion, and hanging from the handles may place undue strain on them. Storing the boat bottom-side down may also cause distortion. Kayak storage systems are available from your dealer. Pad eyes are NOT intended for hanging or for use as tie-downs.

To prevent theft of your kayak, simply run a cable through a scupper hole and lock it to something secure.

## Plug-In Seatbacks

All Hobie Mirage™ seatbacks use a plug-in method of attaching to the hull. Locate the small hole pockets on the seat bottom and press in the plugs attached to the seat backs. Most Hobie kayaks have two sets of holes to allow for more adjustment. New for 2010 are adjustable seat plugs. By turning the top ring you adjust the fit of the plug into the seat plug holes. Do not over tighten, proper tension will allow a snug fit that can still be removed when needed. **We recommend that the seatbacks be removed while car topping your kayak.**



## Transporting Your Hobie Kayak

The easiest way to transport your Hobie kayak is to purchase a roof rack from your dealer. They come with a wide variety of attachments from kayak saddles to stackers. The racks can be used without the attachments but the racks should be padded. To help prevent distortion, place the kayak, cockpit side down, on top of the rack. Straps can then be laid across the boat and tied to the bars. Saddles cradle the boat and often come with their own straps.

An alternative to traditional rack systems are soft racks. They tend to be less expensive and will work with most cars. These

are pads mounted on straps that sit between the kayak and the roof of your car. Some styles have a strap that wraps around the kayak and others strap the pad to the roof. To tie the boat to the car, straps are run through the car doors and the boat is tied to the roof as well as the bumpers, front and rear. Over-tightening the straps may cause dents in the roof of the car. Be sure to first consult your owner's manual for the car and roof rack system to ensure that you comply with all of their recommendations, precautions and specifications.

***A line run from the bow and stern of the boat to each bumper is required.*** If your bumpers do not have a gap to pass a rope around, look underneath. There should be a loop of metal, which is used by car transports such as tow trucks.

Many people like to use the scupper holes to tie the boat to the car. This helps prevent the boat from sliding back and forth or the tie-down rope from slipping off the kayak. This is a perfectly acceptable method for tying the boat down.

## About Polyethylene

Continuing Hobie's tradition of offering the latest in technology at an affordable price, your new kayak is made of rotomolded Super Linear Polyethylene II. Polyethylene offers a major advantage because it is virtually indestructible under normal use. Being somewhat flexible, it gives on impact and derives its stiffness from compound curves. Polyethylene is very abrasion-resistant.

# Frequently Asked Questions

## How can I replace the screw-in fittings (if equipped)?

You may find it necessary to replace some of the pad eyes or hooks if they are damaged. To replace them, follow the instructions below.

1. Drill two 3/16" holes opposite one another on the top surface of the screw-in fitting. Be careful not to go all the way through the part and into the kayak.

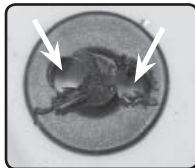

2. Insert the two prongs of a pair of needle nose pliers into the two holes and rotate the part counterclockwise.



3. Grip the new part with your pliers and install it into the hole. Be sure to put a little pressure into the hole so that the threads on the new part install properly.



## Is my boat repairable?

Hobie kayaks are very durable, however, on occasion they may need some minor repairs. Linear polyethylene is repairable. Check with your dealer concerning repairs for your kayak.

## Is my boat recyclable?

Hobie will recycle your boat when you are done with it. To recycle a Hobie Kayak, it must be cut up so it fits in a box with the following dimensions (for UPS): may not exceed 130" length plus girth, and 108" in height. Ship the boat to:

*Hobie Cat Company*  
4925 Oceanside Blvd.  
Oceanside, CA 92056

It is our hope that no Hobie Kayak will ever end up in a landfill!

## What is the best way to use the scupper plugs?

The scupper plugs are useful when you would like to keep the inside of your boat dry and is most helpful in calmer water conditions. Simply press the plug firmly into the scupper hole from the top side of the boat. To prevent loss of the plugs, lanyards are provided with the plugs so that you can attach them to the boat.

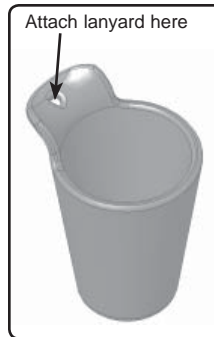

# Warranty Information

**Hobie provides a limited two year hull warranty.**

Your warranty registration card is packaged with this owner's manual and should be completed and returned to Hobie Cat within 30 days of the date of purchase. If you have problems with your boat, contact your dealer first. If you need further assistance, contact Hobie Cat. To help process any warranty problems, please complete your warranty card and give it to your dealer or mail it directly to Hobie Cat.

Hobie warrants each kayak to be free from defects in materials and workmanship for the period listed below. For retail customers in the United States, U.S. possessions and Canada, Hobie will repair or, at its discretion, replace defective parts.

The warranty period for the hull is two years and one year for the Hobie MirageDrive, rudder, seat and paddle.

**This warranty does not cover:**

- Normal wear and discoloration.
- Damage caused by abuse or failure to perform normal maintenance.
- Damage caused by hitting submerged objects or beaching without retracting or removing the MirageDrive and rudder.
- MirageDrive™ Sails are not covered for impact and wear damage.
- Damage caused by mooring or storing boat in water.
- Damage caused by alterations or modifications.
- Transportation of boat or parts to Hobie or its dealers.
- Any boat used as a rental or placed in commercial service.
- Any other consequential damage, incidental damages or incidental expenses, including damage to property. Some states do not allow the exclusion or limitation of incidental or consequential damages, so the above limitation may not apply to you.

**To Obtain Warranty Service:** Within 30 days of discovering a defect, take your boat, along with the proof of purchase (sales receipt) to the authorized Hobie dealer from whom you purchased your boat, unless you have moved or are traveling. In that case, take it to the nearest authorized Hobie Kayak Dealer.

**Implied Warranties:** Any implied warranties, including implied warranty of merchantability and fitness for a particular purpose, shall be no longer than the duration of this express warranty. Some states do not allow limitations on how long an implied warranty lasts, so the above limitations may not apply to you. Hobie makes no express warranties in addition to this limited warranty. Hobie Dealers have no authority to make warranties on behalf of Hobie Cat Company in addition to, or inconsistent with, those stated herein.

To the extent any provision of this warranty is prohibited by Federal, State or Municipal law and cannot be preempted, it shall not be applicable. This warranty gives you specific legal rights.

REV 7/08  
PN 89500

HOBIE CAT  
4925 Oceanside Blvd.  
Oceanside, CA 92056  
Phone (760) 758-9100  
Fax (760) 758-1841

[www.hobie kayaks.com](http://www.hobie kayaks.com)

 H O B I E

[HOBIEKAYAKS.COM](http://HOBIEKAYAKS.COM)

